

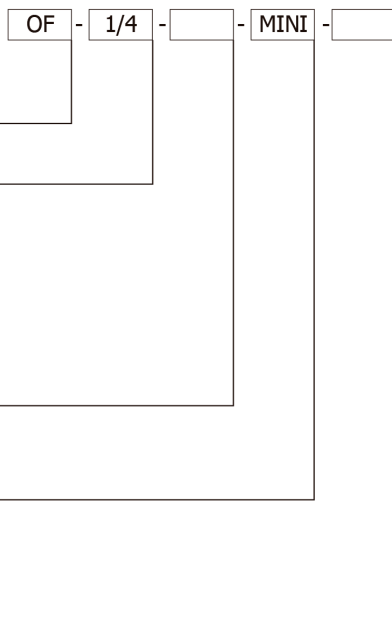

分水过滤器能过滤空气中的液态油、冷凝水及杂质，对于特殊应用场合，5 μm 滤芯容易替换40 μm 的标准滤芯。

The OF with water separator cleans the compressed air of fluid oil, condensation and dirt particles, for special application, the standard 40 μm filter element may easily be replaced by a 5 μm filter element.



基本功能 Basic function

OF	过滤器 Filter
----	------------

接口尺寸 Connection

1/8	G1/8
1/4	G1/4
3/8	G3/8
1/2	G1/2
3/4	G3/4
1	G1

过滤等级 Grade of Filtration

	40 μm
5M	5 μm

规格 Size

MINI	小型
MIDI	中型
MAXI	大型

排水阀 Condensate drain

	手动 Turned manually
S	半自动 Semi-automatic
A	自动 Fully automatic

主要技术参数 General technical data									
规格 Size	MINI			MIDI			MAXI		
工作介质 Medium	压缩空气 Compressed air								
结构特点 Features of structure	带水分离器的烧结式过滤器 Sintered filter with water separator								
安装方式 Mounting type	管式安装或支架安装 Pipe mounting or foot mounting								
安装位置 Assembly position	垂直方向 ±5° Vertical ±5°								
连接尺寸 Connection	G1/8	G1/4	G3/8	G3/8	G1/2	G3/4	G3/4	G1	
标准额定流量 Standard nominal flow rate	OF-... (-A)	1000	1200	1400	2700	3000	3000	5000	5300
	OF-...-5M- (-A)	600	950	1100	1800	1900	1900	3200	3300
输入压力 Primary pressure	手动排水阀 Manual condensate drain	最大16bar Max: 16bar							
	自动排水阀 Automatic condensate drain	1.5~12bar							
过滤精度 Grade of filtration	40 μm / 5 μm								
最大凝露容量 Max. condensate capacity	22ml			43ml			80ml		
温度范围 Temperature range	0~60℃								
材料 Materials information	壳体: 压铸锌; 过滤杯: PC; 金属保护罩: 铝合金; 密封: 丁腈橡胶 Housing: Zinc die-casting; Filter bowl: PC; Metal bowl guard: Aluminium alloy; Sealing: NBR								

尺寸图 Dimensions

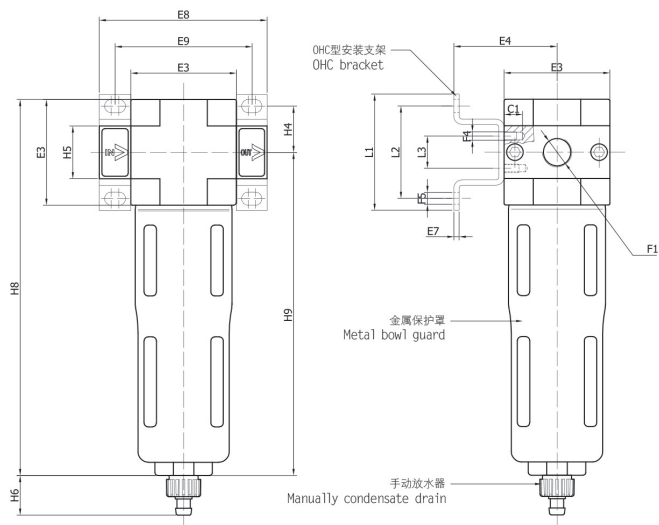

型号 Model	E3	E4	E7	E8	E9	F1	F4	F5Ø	L1	L2	L3	H4	H5	H6	H8	H9
OF-...-MINI	40	39	2	64	52	G1/8,G1/4,G3/8	M4	4.5	44	35	11	17.5	20	15	144	129
OF-...-MIDI	55	47	3	85	70	G1/8,G1/2,G3/4	M5	5.5	71	60	22	24.5	32	15	179	156
OF-...-MAXI	66	53	3	96,116	80,91	G3/4,G1	M5	5.5	71	60	22	24.5	32,40	15	203	175

标准额定流量qn和输出压力p2的关系 Standard flow rate qn as a function of the output pressure p2

OF-1/4-MINI

OF-1/2-MIDI

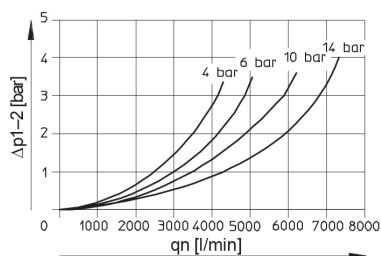
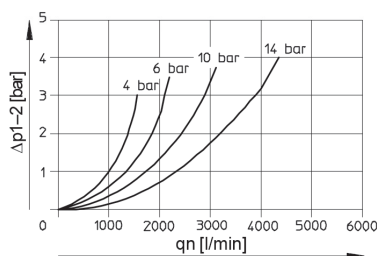

OF-1-MAXI

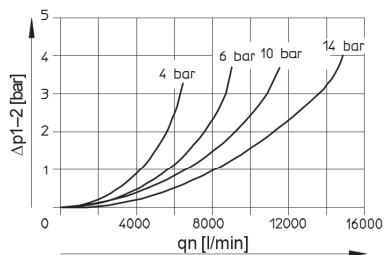

内部结构图 Inner structure

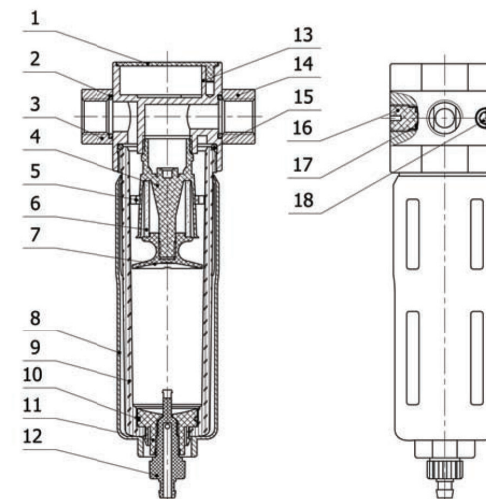

序号 NO.	名称 Item	材料 Material	序号 NO.	名称 Item	材料 Material
1	装饰盖 (圆型) Ornament cover(round)	POM	11	内接头 Inner joint	POM
2	O型圈 O-ring	NBR	12	放水器 Condensate drain	POM
3	分气块-IN Flange - IN	锌合金 Zinc alloy	13	OF 阀体 OF Body	锌合金 Zinc alloy
4	滤芯座 Filter element base	POM	14	分气块 OUT Flange -OUT	锌合金 Zinc alloy
5	旋风叶轮 Whirl wind impeller	POM	15	O型圈 O-ring	NBR
6	滤芯 Filter element	聚乙烯 PE	16	丝堵 Plug	POM
7	挡水板 Manger	POM	17	O型圈 O-ring	NBR
8	保护罩 Metal bowl guard	铝合金 Aluminium alloy	18	内六角螺丝 Allen screw	S35C
9	水杯 Filter bowl	PC			
10	O型圈 O-ring	NBR			